

 Create pdf

Lampholders for compact fluorescent lamps

26.745.1331

G24 / GX24

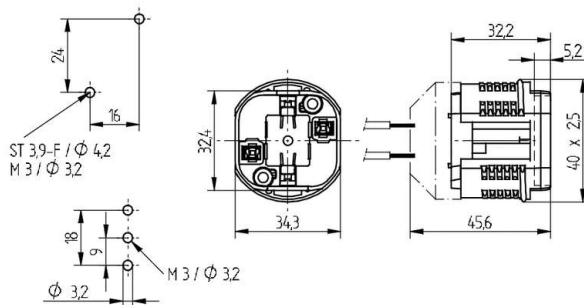

colour	pkg.	wt.	part no.
white	250	15 g	26.745.1331.50

Key: d-3 (26 / 32 Watt)

Approval: additional cULus

For lamps TC-D, TC-T



Screw fixing

Einclipsbefestigung

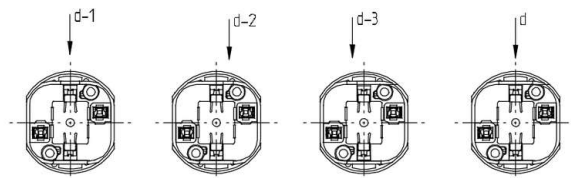
Housing: PBT



- Threaded barrel
- Screw fixing vertical, diagonal: two holes \varnothing 3.2 mm
- Panel cut-out: 2 holes, distance 16 x 24 for self-tapping screws ISO 1481 - ST 3.9 - F
- Screw fixing central, vertical: one hole \varnothing 3.2 mm and 2 anti rotation slots
- Panel cut-out: three holes 2 x 9 = 18 mm for screws ISO 1207 - M3
- Rivet fixing: we recommend blind rivet \varnothing 3.0 mm according to DIN 7337 (Aluminium / Steel flat round head) max. pull force 500 N

T 140		 0.5 - 1.0 mm ²	 18 AWG 0.5 - 1.0 mm ²
-------	---	--	--

Document generated on: We, 8. February 2017 - 16:31